

Specification Sheet

CX400 Sweeper

Series CX400 Mid Range Sweeper

Sheet: 1 of 2

Date: January 2010

Subject Technical Information & Data



Capacity	
Hopper voided volume	4.1m ³ , 4003 stainless steel hopper
Payload capacity*	3.6m ³
Fuel tank	95 litres
Ad blue tank	20 litres
Lost water tank	600 litres

Sweeping Equipment	
Brush diameter	1000mm
Brush speed	Variable up to 125rpm
Nozzle width	850mm
Sweep rate/output	40,000m ² /h (theoretical)
Hopper discharge height	Standard 1100mm High dump up to 1800mm high skips

Engine Data	
Model	Iveco N40 ENT Common rail direct injection turbocharged diesel
Cubic capacity	3.92 litres
Number of cylinders	4
Gross rated power	118kW @ 2700rpm
Maximum torque	530Nm @ 1200rpm
Legislation compliance	Meets Euro 5 emissions legislation Directive 2005/55/EC

Performance	
Tare – std machine	4940 kg
GVM – std machine	7500 kg
Payload – std machine	2560 kg
Tare – high dump	5240 kg
GVM – high dump	7500 kg
Payload – high dump	2260 kg
Max speed	up to 80km/h
Sweeping speed	0.5 ~ 16km/h
Gradeability	> 24% fully laden

*Subject to loading conditions and waste type.



MacDonalD Johnston Pty Ltd ABN 68 004 992 090 65-73 Nantilla Road, Clayton North, Vic. 3168 Australia.

Head Office +61 (0)3 9271 6400 Melbourne +61 (0)3 8558 3600 Sydney +61 (0)2 9756 1622

Adelaide +61 (0)8 8168 2222 Brisbane +61 (0)7 3363 6400 Perth +61 (0)8 9271 8455

information@macdonaldjohnston.com.au www.macdonaldjohnston.com.au

Due to continuous product development MacDonalD Johnston reserves the right to alter specifications without prior notice.



Technical Specification

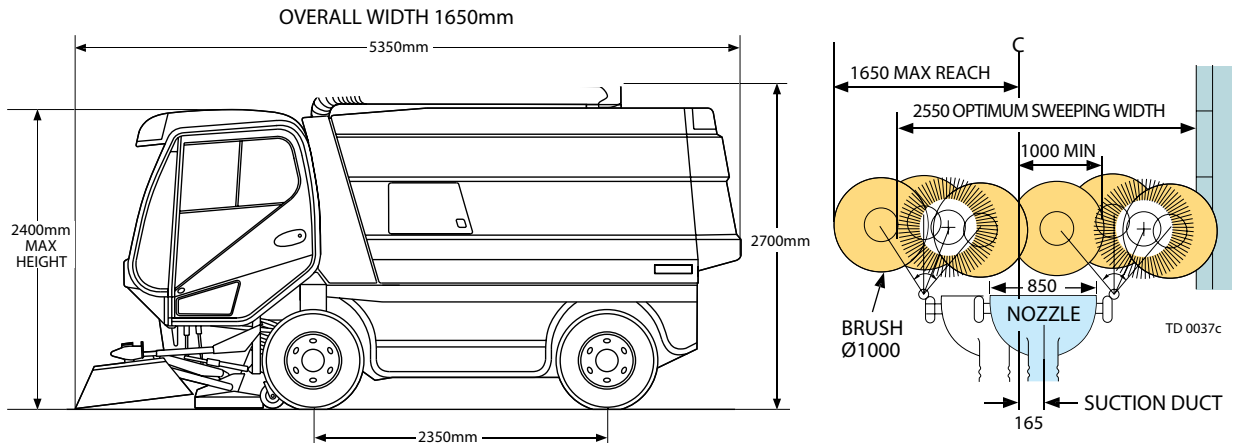

Base Specification

Transmission

Full hydrostatic transmission with closed loop circuit and variable angle swash plate axial piston pump and motor. Maximum transit speed up to 80km/h and maximum sweeping speed of 16km/h.

MegaJET engine control

Innovative Johnston transmission control system providing full automotive drive in transit mode, forward/reverse selection with slower 'tortoise' speed feature for sweeping applications complete with anti-stall software.

Electrics

24 volt system with 95 amp alternator

Suspension standard

- Front: Linkage system comprising V link and two reaction rods, plus axially mounted coil springs and bump stop with shock absorbers.
- Rear: Two single parabolic leaf springs, rubber cone spring assistors acting as bump stops.

Steering

Full power assisted steering, 55° steering lock angle. Turning circle 7700mm kerb to kerb.

Tyre size

- Front: 245/70 R17.5 Radial ply tyres
- Rear: 245/70 R17.5 Radial ply tyres

Brakes

Power assisted hydraulic disc brakes with split circuit for added security on front axle as standard.

- Front: Twin four piston disc brakes fitted to each wheel.
- Rear: Single four piston disc brakes fitted to each wheel.

Parking: Transmission disc brake on the drive motor shaft is operated by cab mounted handbrake.

Noise

- In cab: Noise between 70 – 74 dB(A), depending on operating conditions.
- External: Maximum L_{WA} of 109 dB(A) measured in accordance with Directive 2000/14/EC.

Impeller

High pressure centrifugal fan unit mounted to hopper roof provides powerful suction means for the pickup nozzle and duct conveying system. Driven by hydraulic motor with integral heavy duty support bearing. Dynamically balanced multivane low noise fan impeller with wear resistant blades

Hopper

All 4003 stainless steel welded construction combining the suction fan impeller, filter meshes and debris collection hopper.

Cab

- Air conditioning.
- Heater: Recirculating air type with face and floor level vents with fresh air intake option.

Seating: Fully adjustable air suspension cloth covered driver's seat with adjustable back support and matching passenger seat with 3 point seat belts.

Controls: Ergonomically placed switches, clustered according to function. Adjustable arm rest incorporating sweeping controls. Overhead console incorporating lighting switches, CANview display and radio/MP3 player.

Central control deck containing ignition switch and heater controls.

Hopper tipping pendant.
Door mounted switches for suction fan and Supawash.

Standard features

- Attention Warning System: Alerts the driver in the event of a system problem.
- Beacon: Four rotating beacons mounted on each corner of the bodywork.
- Hopper Tipping Pendant Control: Giving safe observation of the tipping zone.
- Independent brush pressure control and positioning.
- Stereo radio/MP3 player with 45 watt dual cone speakers.
- Reverse warning: Audible warning device with night silent override.
- Weight load indicator.
- Wheeled nozzle with replaceable rubber tyres.
- Supawash: High pressure washing hand lance and pump (28 litres @ 100 bar).

Options

- Battery isolator.
- CCTV reverse camera system.
- High dump: Load discharge into skips (7500kg only).
- Hydrant hose, standpipe and key: Side mounted flexible duct for litter collection.
- Radio/CD upgrade.
- Wanderhose: Roof mounted with 4.5m working radius.
- Groenveldt autolube system.
- Detergent injection for supawash.